

# RELIABLE CRANE SCALES

## Digital Crane Scale - 10000 KG

## RELIABLE-YUBO

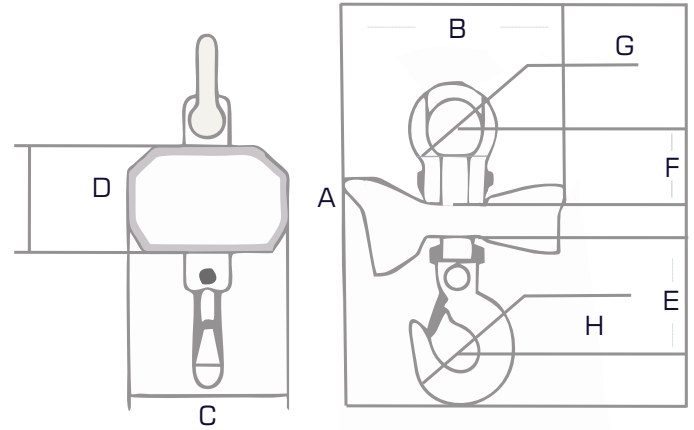

	A	B	C	D	E	F	G	H
10T	645	320	235	160	240	170	90	80

mm

### Specification

- ◆ Super bright 5-digit 1.2 LED display
- ◆ Measures : Standard remote controller to perform Calibration, Hold, Zero & Division selection functions.
- ◆ High capacity rechargeable battery (6V/4Ah).

### Advantages

Using high quality large scale integrated circuit, ensure excellent measurement performance and stability for a long time. It has accumulated, delete, query, keep, division value switching, unit switch, automatic shutdown, and automatic battery monitoring function.

### Application

This product is widely used in ports, transportation, metallurgy industry, steel market, building materials market, storage, coal, paper making, mining enterprises and other areas of loading and unloading cargo measurement, process flow measurement, raw materials in and out of measurement and warehouse stock measurement.

### Technical Parameters

Class of accuracy	GB/T11883-2002=Electronic crane scales III
Tare range:	Maximum capacity 100%
Zero range:	Maximum capacity $\pm 20\%$
Stable time:	10 sec
Overload alarm:	Maximum capacity 100%+9 GRDN
Max safety load:	Maximum capacity 150%
Battery Spec:	6V/4Ah lead-acid battery
Charge: Operation	AC220V input, DC1.2V/500mA output
Temp °C :	10°C~+40°C
Display screen:	Ultra-high brightness digital tube 0.8inch /1.2 inch LED display.
Remote control:	4 key remote control.

## Complete Range of Static & Dynamic Weighing Solutions

**E-mail:** [info@reliablegulf.com](mailto:info@reliablegulf.com)  
**Website:** [www.reliablegulf.com](http://www.reliablegulf.com)

**Tel:** +971 4 289 6005  
**Fax:** +971 4 289 6605

Sultan Khalifa - Al Habtoor S-08, Ras Al Khor, Nad Al Hamar, Dubai, UAE