

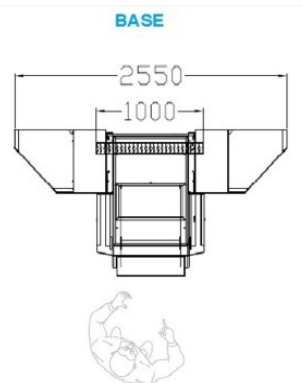

X-RAY INSPECTION SYSTEM

FOR FOOD INDUSTRY

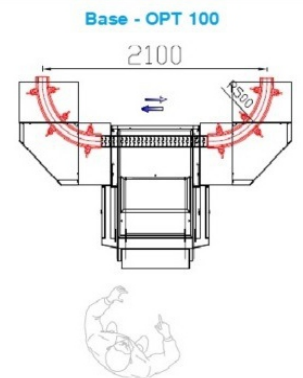
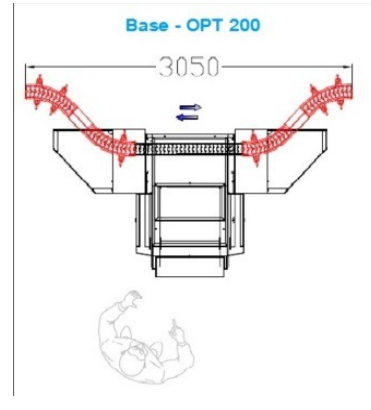

Description	Value
X-ray generator	MAX 2 x 500W/90kV - Water cooled
Inspection mode	Single view "Microfocus"
Length, Width, Height	L 2550 x W 1450 x H 1550 (incl. standard tunnels)
Weight	Kg 650 (incl. standard tunnels)
Power supply	220V, AC, 50/60Hz - power consumption 3 kW
Max- inspection speed	20-60m/min
Max. product dimensions	Ø 120 mm, H 215 mm detector 256x0.4 Ø 170 mm, H 270 mm option detector 400x0.4
Inspection conveyor width	Table Top: 83 - 114 - 190
Reject table	Gravity rejection mode
Equipped with sensor to check the correct ejection	Motorized conveyor option: 170mm. x 1000mm
Pneumatic reject system	(1200 bpm.), double rejection - deviator and ejector